

STEP 1 : Removing the PHP-2026 Massage Chair

- Remove the chair from carton box
- 2 or more people are needed to lift and remove the chair, according to the holding areas shown in the diagram below.

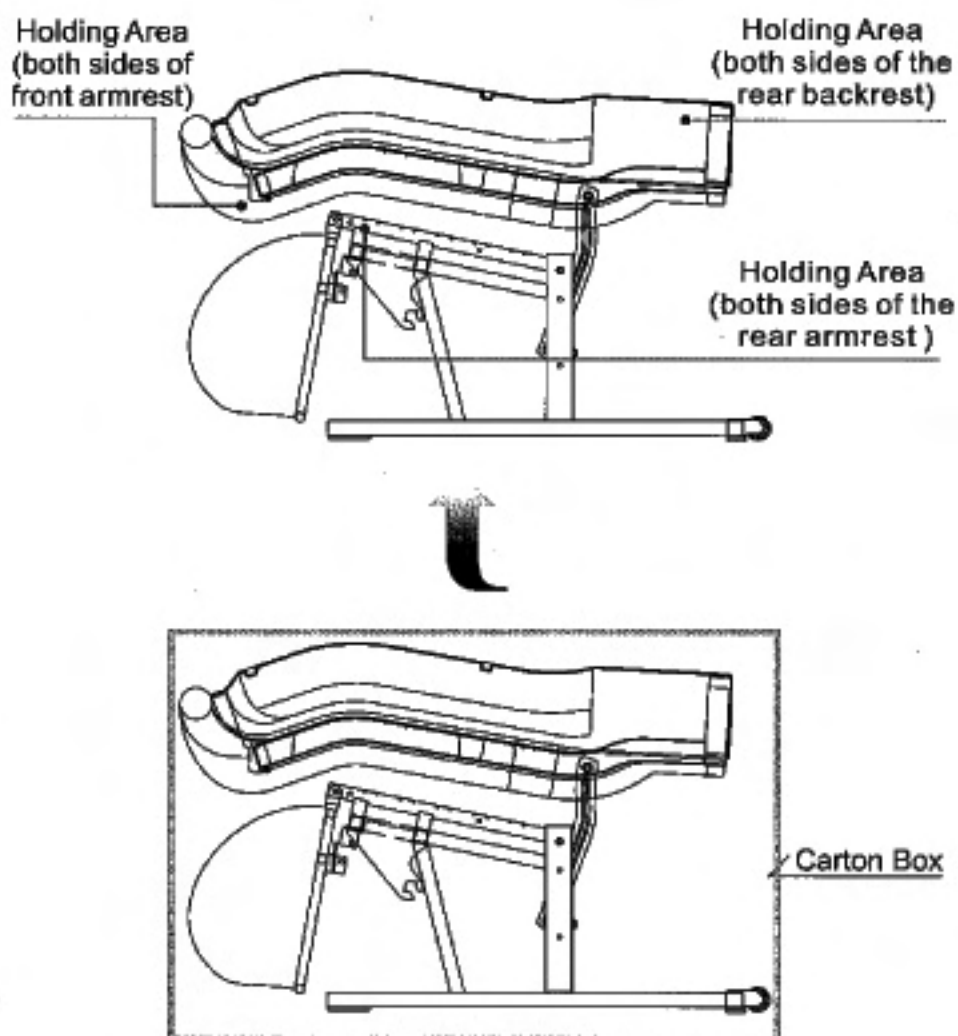

STEP 2 : Setting Up The Massage Chair

- When the massage chair is removed from the carton box, upright the backrest
- Upright the backrest to approx. 120 degrees, until a "CLICK" is heard, to fix the backrest.

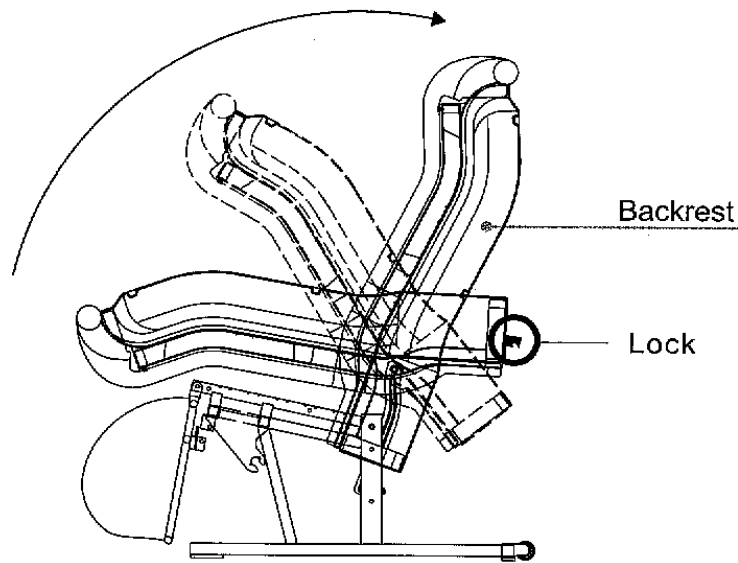

STEP 3: Setting Up The Back Pad

- Place the back pad at the position where the zipper is on the backrest then zip up.

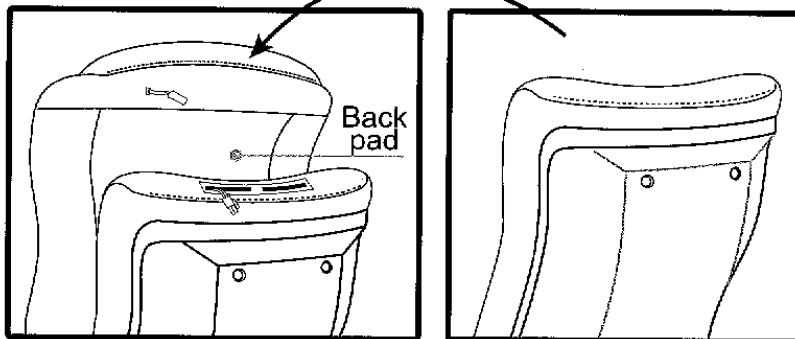

STEP 4 : Setting Up The Back Warmer

- Attach the wire from the back pad (Male end) to the one from the backrest (Female end) .
- Stuff the spare length of wire into the gap on the top of backrest, and zip up the zipper, the back pad is now set up.

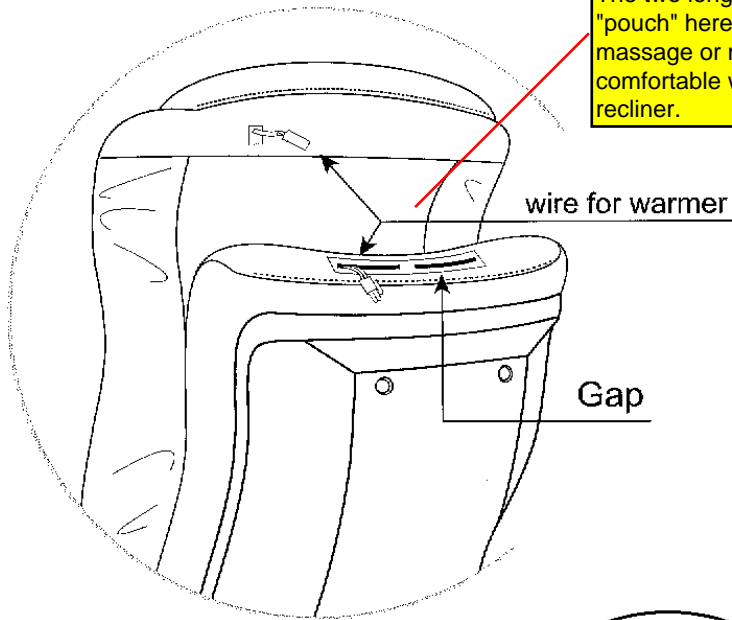

The two long black cushions can go in the "pouch" here to lessen the strength of the massage or make the chair more comfortable when in use as a normal recliner.

✳ Setup Finished

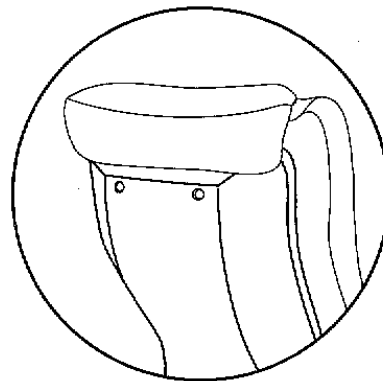

Finished

STEP 5 : Instruction For Assembling The Armrests

- Assemble the armrests by inserting them to the 3 metal pipes at two sides of the seat frame .
- Apply the two flying nuts onto metal rods (on the armrests)

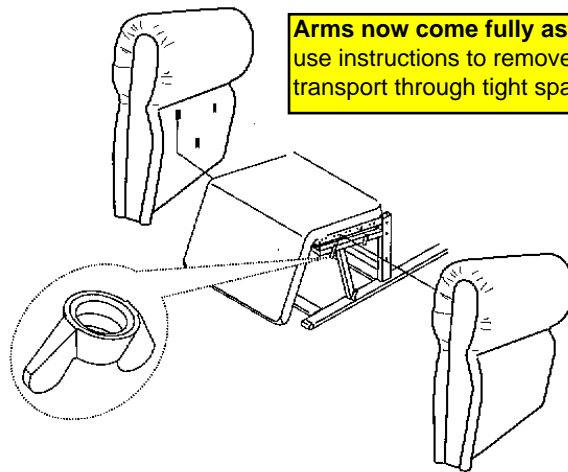

Arms now come fully assembled, use instructions to remove arms for transport through tight spaces.

STEP 6 : Setup Completed

- When the above assembly is done as instructed, plug in the power wire as in the picture and switch on the power. The chair is now ready to be use, and to serve you with relaxing and comfortable massage.

